



F-Series
Radial Pressure & Vacuum Blowers





F-CEV-S / F-CEV-D



F-CEVF (29)



F-CEVF (31)



F-RER / F-REL

Product overview

F-CEV-S

Radial blowers with three to five stages for vacuum operation

Capacities up to 328 cfm and vacuum up to 46.2 in. H₂O.

Compact design, low temperature operation even when throttled. Fast start-up due to light weight impellers.

F-CEV-D

Radial blower with three to five stages for pressure operation

Capacities up to 328 cfm and pressure up to 50.2 in. H₂O.

Compact design, low temperature operation even when throttled. Fast start-up due to light weight impellers.

F-CEVF (29)

Multi stage radial blowers for vacuum operation

Capacities up to 177 cfm. Total pressure difference up to 36 in.

H₂O. Complete with filter and dust separator. Suitable for removing paper powder and dust.

F-CEVF (31)

Multi stage radial blowers for vacuum operation

Capacities up to 275 cfm. Total pressure difference up to 28 in.

H₂O. Complete with high filter vessel and collection bin. Suitable for removing paper, film or plastic trim scrap.

F-RER / F-REL

Single stage radial blowers for vacuum and pressure operation

Capacities up to 2,013 cfm and vacuum up to 38.3 in. H₂O, pressure up to 39.9 in. H₂O.

Solid light weight construction. Vibration free and quiet running. The bearings are greased for life and need no servicing. Available in left or right hand configurations for maximum installation flexibility.

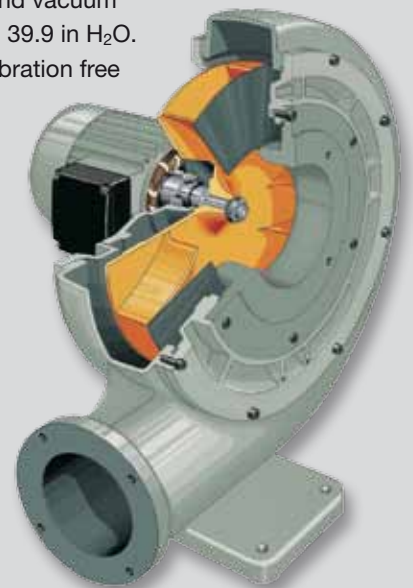

Side channel blowers

Elmo Rietschle offers a wide range of single and multi-stage radial blowers for vacuum and pressure operation.

F-CEV multi-stage radial blowers

These blowers are available for suction (F-CEV-S) and pressure (F-CEV-D) mode and cover a wide range of industrial applications.

F-CEV versions include either a small dust collection canister or a large canister for the collection of plastic or paper trimmings.

F-RER and F-REL single stage radial blowers

These blowers come in a wide variety of sizes and can be used for both suction and pressure mode in many industrial processes where high volume flow at small differential pressures are needed. Variable frequency drives are available.

When it comes to installing these blowers, you will find that any position (left/right/vertical/horizontal) is possible. F-RER blowers are right turning, F-REL left turning for maximum flexibility in cases where space is essential (such as in central air cabinets).

Advantages at a glance

- Cast aluminum housings and impellers
- Reliable, and economic operation
- Greased for life bearings
- Quiet operation
- Process safe (no reverse contamination)
- Variable speed drives available
- Low maintenance

Technical specifications

Operating principle

As the impellor rotates, the air in the blade chamber (1) of the impellor (2) is centrifugally moved outward and exits at the edge of the impellor (3). This creates negative pressure at the hub of the impellor (5) causing air to flow in from the inlet port (4). This incoming air is deflected from an axial into a radial direction as it enters the blade chambers (6). Due to the high speed of the impellor, the air flows outward into the spiral housing (7). At this point the velocity is reduced and part of the energy is transformed into compression energy. The air then exits through the outlet port (8) of the blower.

